

**PRIMARY
PACKAGING**

HPS 50

Electronic Flow wrapping Machine



INDUSTRIES



PACK STYLES

PILLOW PACK



GUSSETED PACK



OFFSET FINSEAL



STANDARD FEATURES

The Sacmi HPS50 flow wrapping machine is a fully electronic controlled machine

The machine is highly flexible, user-friendly, providing easy product changeover and easy integration in automatic packaging line.

Designed and assembled with high quality standard and components; the machine reduces operation cost while minimizing maintenance.

Wrapping material max. linear speed: 50m/min

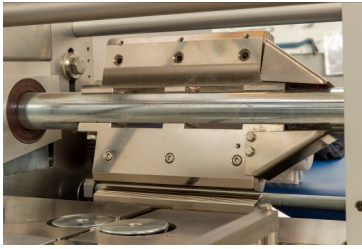

High performance cross sealing head (twin jaws opt)

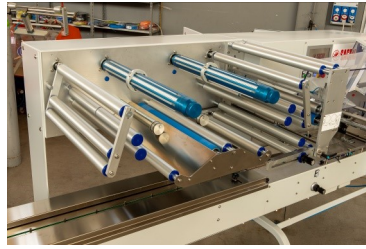

Automatic film reel splicer



Three (3) pairs of sealing rollers, 1st one inclinable



10" color touch screen HMI

OTHER FEATURES

- Machine available in right or left hand version
- Machine available in painted or stainless steel
- Brushless digital servo motors
- Gusseting device
- No product - No bag
- No Gap - No Seal
- Integration with line automatic feeding system

LAYOUT

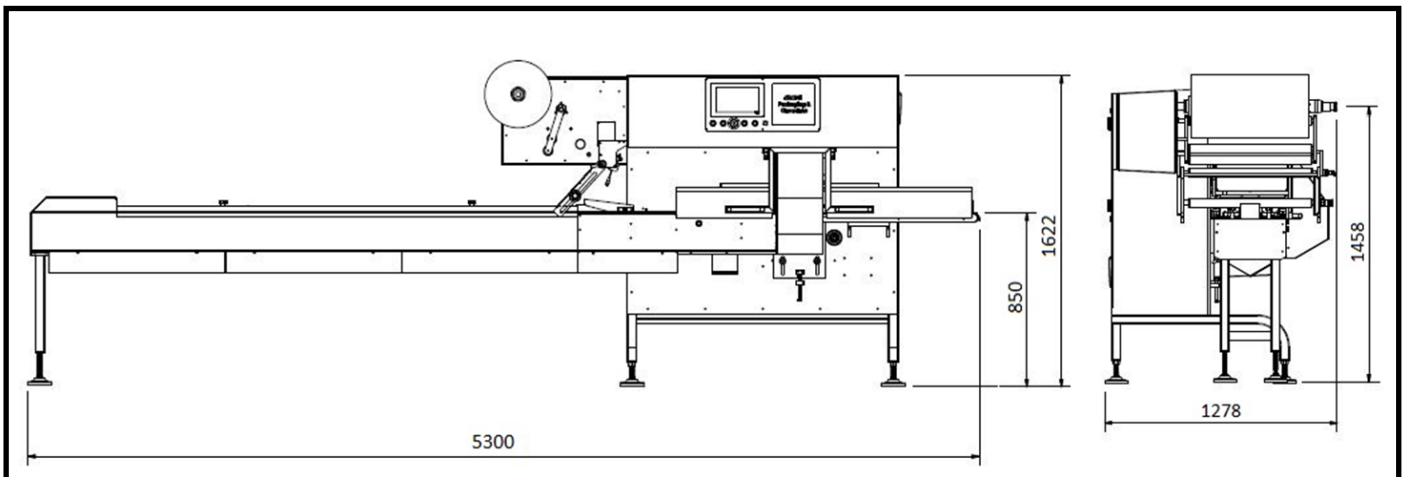

TOTAL WEIGHT	POWER REQ	AIR CONSUMPTION
850 KG	380 V - 50 Hz 5 Kw (double jaws version)	1 NL/min (pneumatic gusseting version)

TECHNICAL FEATURES

WRAPPING MATERIALS	Cold or heat sealable materials, such as polypropylene, barrier films, laminates, paper based films
ELECTRONIC PLATFORM	B&R/ ALLEN BRADLEY (option)

MAX FILM WIDTH	MAX SPEED	Ø FILM REEL	PRODUCT LENGTH	PRODUCT WIDTH	PRODUCT HEIGHT
650mm	350ppm or 50	400	50-550mm	20-150mm	Up to 100mm
800mm	150ppm or 20	400	100-600mm	20-300mm	Up to 140mm



SACMI Packaging & Chocolate S.p.A.
 Sede Legale: Via Selice Provinciale, 17/A - 40026 Imola (BO) Italy
 Sede Amministrativa: Via Trebbia, 22 - 20089 Rozzano (MI) Italy
 Tel. +39 0282452.1 - Fax +39 02 82452252
www.sacmi.it/chocolate www.sacmi.it/packaging