

**PRIMARY  
PACKAGING**

# PS 600

## Vertical Packaging Machine



**INDUSTRIES**



**STYLES**

**PILLOW**



**BLOCK BOTTOM**



**STABILO BAG**



**MULTIPACK**

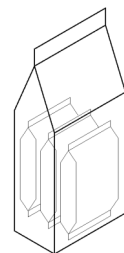

**STANDARD FEATURES**

**The PS 600 intermittent vertical form fill and seal machine is designed to provide various packaging solution, for the food and non-food industry.**

**It is an electronically-pneumatically driven, compact, painted steel machine, with quick and simple change-over and maintenance.**

**PS 600 multipack version, suitable for secondary packaging of already packaged products, with practical bag counting systems.**



**Motorized film unwind**

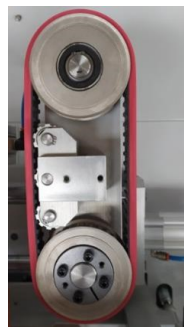

**Pulling belts**



**Cross sealing**



**Vertical sealing bar**

**OPTIONALS**

- **PS 600 multipack version**
- **Multipack conveyors and bag counting systems**
- **Pneumatic square bottom forming system**
- **4 sealing forming tubes (stabilo bag)**
- **Automatic print centering**
- **Automatic reel centering**
- **Industry 4.0 compliance**
- **Eurohole**
- **Integrations with various weighing systems, code daters, labeling and clipping machines**

**LAYOUT**

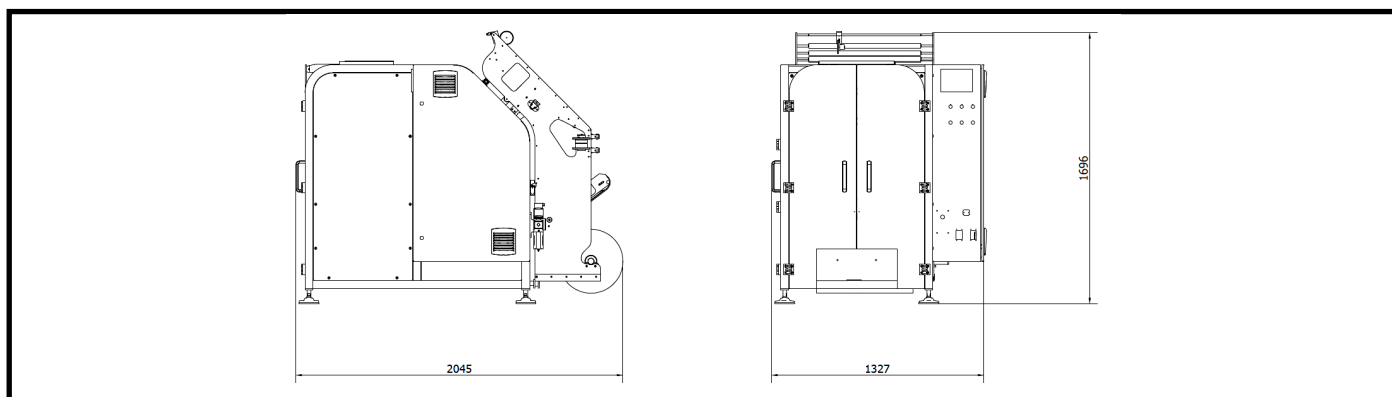

TOTAL WEIGHT	POWER REQ	AIR CONSUMPTION
<b>500 KG</b>	<b>380 V - 50 Hz 3,5 Kw</b>	<b>2,9 NL/cycle</b>

**TECHNICAL FEATURES**

<b>WRAPPING MATERIALS</b>	<b>Heat sealable materials, such as polypropylene, barrier films, laminates, as well as polyethylene films, paper films</b>
<b>ELECTRONIC PLATFORM</b>	<b>ALLEN BRADLEY</b>

MAX REEL WIDTH	Ø FORMING TUBE	MAX BAG LENGTH	FLAT BAG WIDTH	Ø FILM REEL	MAX SPEED	SEALING JAWS MAX CLEARANCE
<b>600 mm</b>	<b>Max. 180 mm</b>	<b>500 mm</b>	<b>295 mm</b>	<b>300 mm</b>	<b>50 cycles/min</b> (dosing machine and product depending)	<b>180 mm</b>



**SACMI Packaging & Chocolate S.p.A.**  
 Sede Legale: Via Selice Provinciale, 17/A - 40026 Imola (BO) Italy  
 Sede Amministrativa: Via Trebbia, 22 - 20089 Rozzano (MI) Italy  
 Tel. +39 0282452.1 - Fax +39 02 82452252  
[www.sacmi.it/chocolate](http://www.sacmi.it/chocolate) [www.sacmi.it/packaging](http://www.sacmi.it/packaging)